

Junttan

Pile Driving Rig

PMz6

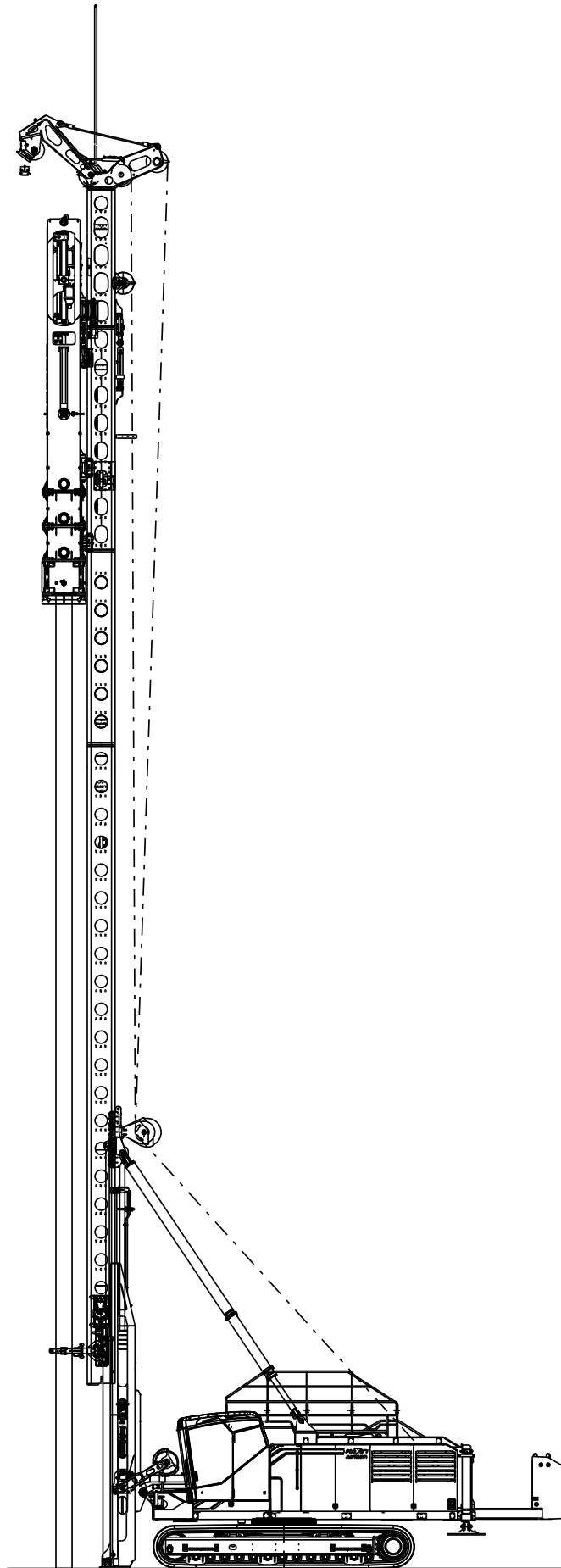

Original
Junttan
product

DATA SHEET

General Information

Junttan PMz6, the new generation of piling rigs is here! This modern piling rig offers you unseen user experience with exceptional performance. New Junttan z-generation user interface takes the use of piling rig to a completely new level. New ergonomically designed cabin offers outstanding comfort for the operator and makes the use of the new rig extremely efficient. With the touch screens and strategically positioned controls, operator truly comes a part of the machine.

With the possibility to do 1:3 inclined piles to all directions, even to the sides, PMz6 offers performance and stability that no other manufacturer can offer. 20 ton leader capacity makes it possible to use up to 9 ton Junttan hydraulic hammers and big winch capacity makes working with the rig fast and reliable. In addition to the new design and new possibilities, Junttan PMz6 offers the same no-nonsense reliability and long life term as all other Junttan piling rigs.

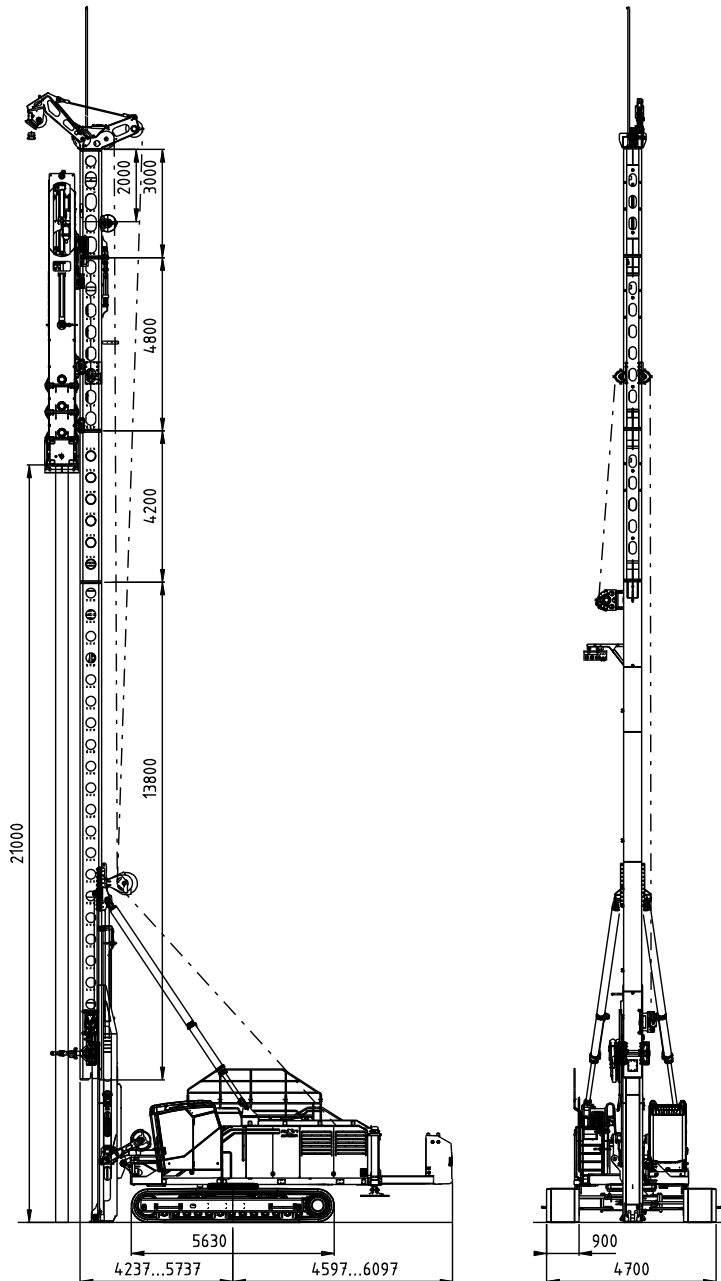

PMz6 with Junttan Hydraulic Impact Hammer HHK5/7/9S

Technical Data

Basic features

Nominal operational weight		86 000 kg	190 000 lb
Maximum leader capacity		20 000 kg	44 000 lb
Winch capacity	Pile:	12 000 kg	26 500 lb
	Hammer:	20 000 kg	44 000 lb
Recommended hammer type	Junttan HHK5-7-9 / SHK5-7-9		
Maximum pile length		26 m	85 ft

Uppercarriage

Type	Junttan PMz6		
Engine	Type:	QSB 6.7 Stage V	EU Stage V / US EPA Tier 5
	Power:	231 kW	310 hp
	Fuel tank:	850 l	225 gal
Hydraulic system	Max flow:	2x280 + 120 lpm/2 000rpm	2x74 + 32 gpm/2 000rpm
	Max pressure:	350 bar	5 075 psi
	Cooling system:	2xHPA52 coolers	
	Oil tank:	750 liters	196 gal
Control system	Junttan Z control system		
Slew drive	1 380 mm double row slewing ring		
Counterweight	Extendable	5 700 + 4 500 kg	12 566 + 9 900 lb

Leader

Type	Telescopic PMz6		
Movements	Telescope	4 000 mm	158 in
	Foot (up/down)	1 000/500 mm	40/20 in
	Horizontal	1 500 mm	59 in
Inclinations	According separate capacity tables Electronic inclinometer included		

Undercarriage

Type	JH57160		
Crawler length		5 700 mm	225 in
Width (900 shoes)	Min:	3 200 mm	126 in
	Max:	4 700 mm	185 in
Track shoe options	Width:	800/900/1 000 mm	31½/35½/39½ in
	Surface:	3-edge / flat edges / flat	
	Edge type:	normal / chamfer / bended	

Accessories

* Side auger JD1,5/JD3	* Air conditioning
* Rear support legs	* Auxiliary winch (5 000 kg / 11 000 lb)
* Automatic central lubrication	* Generator
* Arctic kit	* Air compressor
* Hammer pull down system	

* Contact Junttan sales for all available options and accessories

Transport Dimension

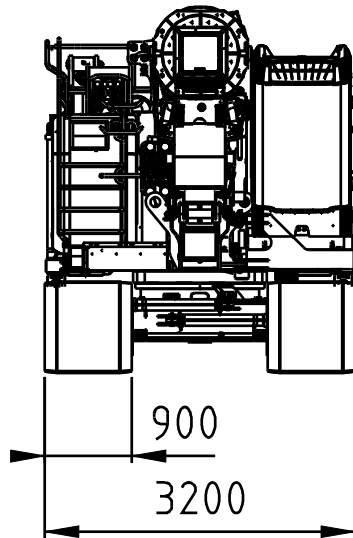

Minimum track width.

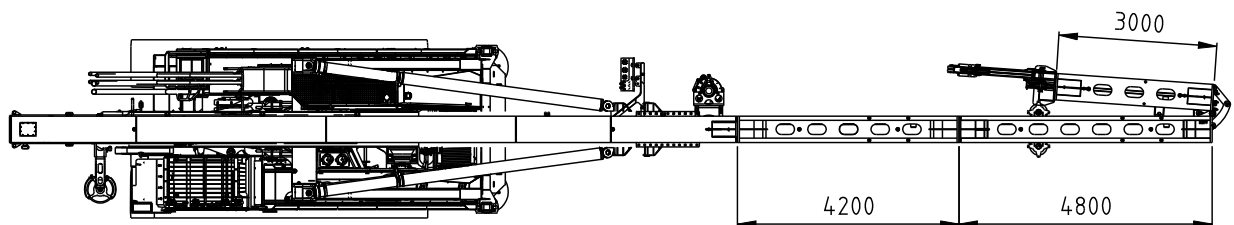
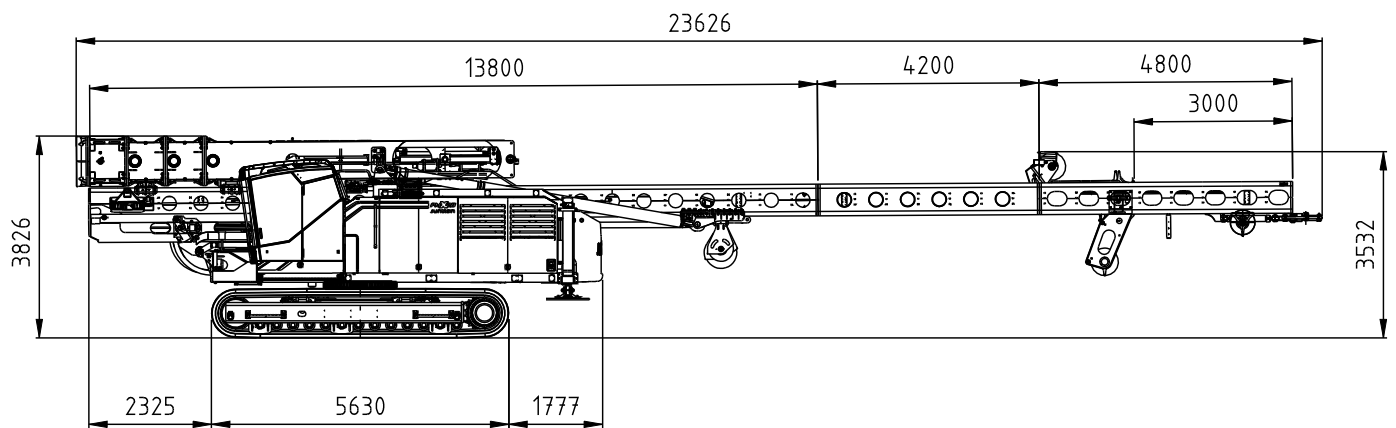

PMz6 transport dimensions with Junttan Hydraulic Impact Hammer HHK5/7/9S

Junttan

Junttan Oy
P.O. Box 1702 (Matkuksentie 7)
FI-70701 KUOPIO, Finland

Tel. +358 10 195 221
junttan@junttan.com