

TECHNICAL DATA

COLD PLANER (TIER 3)

BM 2000/58

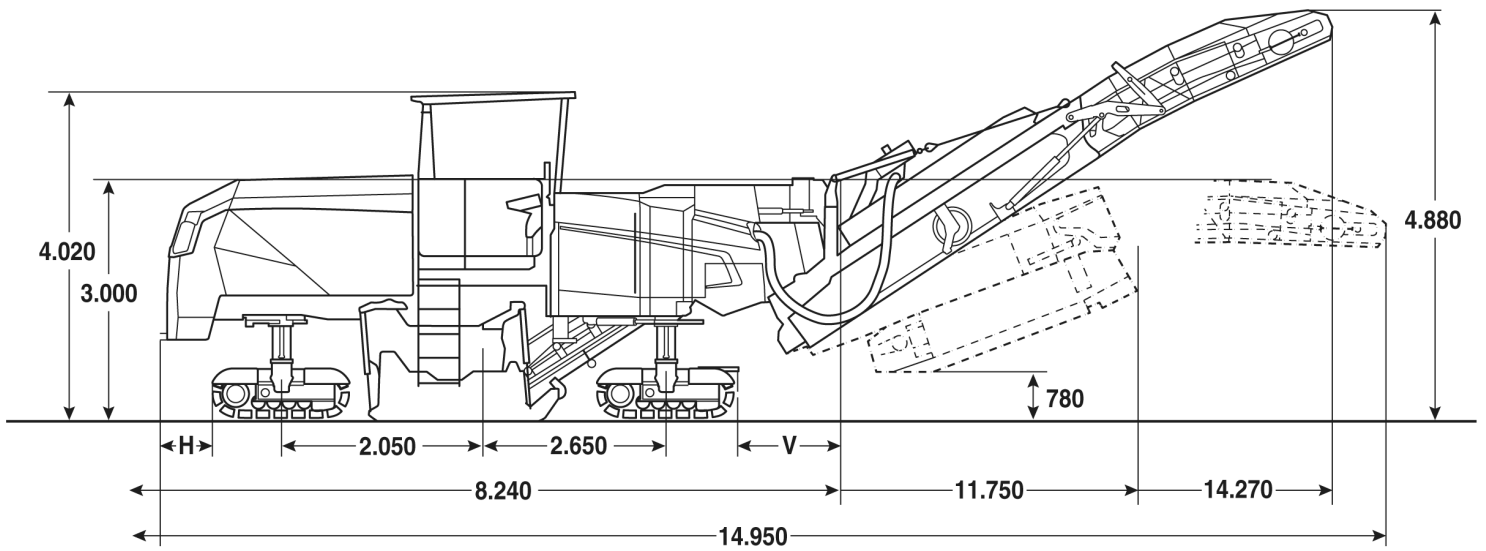



H: **V:**
B1 = 790 **B1 = 760**
B3 = 860 **B3 = 840**

FB:2.000 = R_{min} 13.500

A:
FB:1.500
= 2.500
FB: 2000
= 2.500
FB:2.200
= 2.700

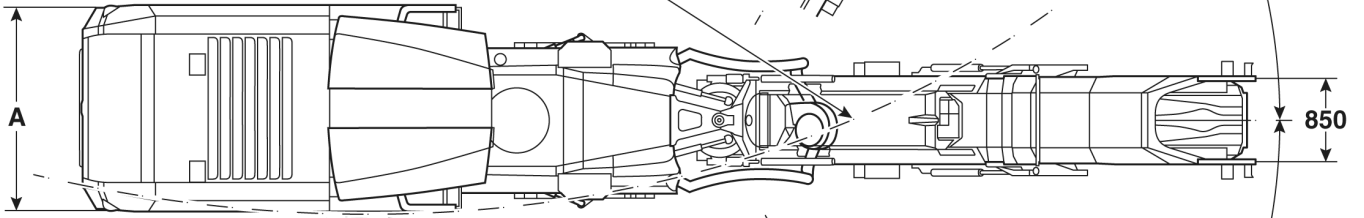

FB:2.000 = R_{min} 1.700

65°

65°

Technical Data

Milling Drum Speed

Working width max..... mm	2.000
Working depth..... mm	0 – 350
Linespace..... mm	18
Cutting diameter..... mm	1.020
No of tools	148
Milling drum speed..... min ⁻¹	variable, 90, 105, 115

Drive Train

Manufacturer	Cummins
Type	X15
Cooling	Liquid
Cylinders / Displacement..... cm ³	6 / 14.900
Performance..... kW / PS	449 / 610
Idle at rated Power..... min ⁻¹	1.900
Max Torque..... Nm / rpm	2.778 / 1.400
Fuel consumption, at max Torque / at rated Power..... g/kWh	218 / 1.900
Generator..... V / A	24 / 190
Battery..... V / Ah	2 x 12 / 200
Emission level	Tier 3

Driving Characteristics

Transport Speed..... km/h	0 – 6
Working speed..... m/min	0 – 100
Crawlers (B1)..... mm	1.550 x 270 x 595

Capacities

Fuel..... l	1.200
Water..... l	3.250
Hydraulic oil..... l	200

Loading System

Conveyor width, inner /outer..... mm	850 / 850
Theoretical discharge capacity..... m ³ /h	485
Discharge height..... mm	4.880

Weights

Max. Operating Weight (incl. Options)..... kg	33.400
Operating Weight CECE..... kg	27.000
Basic Weight..... kg	24.650

Additional weights for Options

Canopy..... kg	370
Dust reduction system..... kg	160
Compressor..... kg	50
Ballast 1..... kg	975
Ballast 2..... kg	830
B3 Track..... kg	600
Auxiliary unit..... kg	150
Scanning FW..... kg	130

BOMAG BM 2000/58

Technical modifications reserved. Machines may be shown with optional accessories. Actual machine weight depends on the respective configuration.

Standard

Milling technology

- Milling drum LA18 including wear protection on the sides
- BOMAG BMS 15 EVO exchangeable toolholder
- 3 Milling-Drum-speeds, 90, 105, 115
- Proportional adjustable water injection
- Levelling, 2 sides + slope
- Wear-free, digital Milling depth display
- Proportional Milling depth adjustment
- Two proportional speeds for Milling-depth-adjustment
- Hydraulically operated side-plates with 500 mm (right) and 400 mm (left) stroke
- Hydraulically operated front mouldboard
- Hydraulically rear mouldboard with adjustable preload-pressure
- Right side-plate for fast Drum-exchange
- Automatic load-control
- Automatic distribution of traction
- Hydraulically foldable Conveyor with +65° swivel angle
- Camera system: 1x discharge belt; 1x on the back
- BOMAG Dual Filtration
- BOMAG Easy Cut
- BOMAG Easy Level

Drive Systems

- 4 crawler B1 size steerable, front or/and rear
- Crab walk
- Variable transport speed
- Variable operating speed
- Mechanical Drum-drive

Operation comfort

- Fully vibration-isolated operator-platform
- Comfort zones at the standing areas for fatigueless operation
- Adjustable dashboards
- Standardized self-explanatory, well-arranged dashboards
- Large storage at ground level
- Service- and maintenance-points ergonomic concentrated
- Large Storage compartment at the operator platform including 24V plug and flexible layer
- Diesel fill comfortable and safely place at the operator station
- BOMAG Fast Select for a fast machine operation

Safety & environmental protection

- Noise optimized design
- Liquid cooled engine following latest emission rules without hot exhaust jet to the back
- Integrated working lights – 37.500 lm
- Rotary-beacon
- Mirrors
- Back-up-alarm
- TELEMATIC

Optional

Basic machine

- Track chains B3 size
- Storage compartment for cutting tools on the track chains
- Weather protection roof
- Plexiglas weather protection for the side railings
- Water filling pump
- High pressure cleaner
- Hose reel
- Dust reduction system
- Milling drum turning device for easy tool change
- Compressed air system
- Additional motor for auxiliary function & emergency drive function
- Ballast weights
- Slewable standing support
- Vandalism protection

Milling technology

- Quick-exchange drum-system
- Milling-Drum 2000, BMS 15 EVO, LA18
- Milling-Drum 2000, BMS 15 EVO, LA6
- POWER DRUM 2000, BMS 15 EVO, LA23

Levelling Systems and electronic support

- Additional external BOMAG Easy Level Display
- 2 scanners left & right in front of the milling box
- Camera system: 2 additional camera's: 1x downholder; 1x rear scraper
- BOMAG TELEMATIC

